

THIS DRAWING IS UNPUBLISHED. RELEASED FOR PUBLICATION
 © COPYRIGHT BY TYCO ELECTRONICS CORPORATION. ALL RIGHTS RESERVED.

LOC	DIST	REVISIONS			
P	LTR	DESCRIPTION	DATE	DWN	APVD
FT	47	R	OG3B-0344-03	29APR03	TK GS

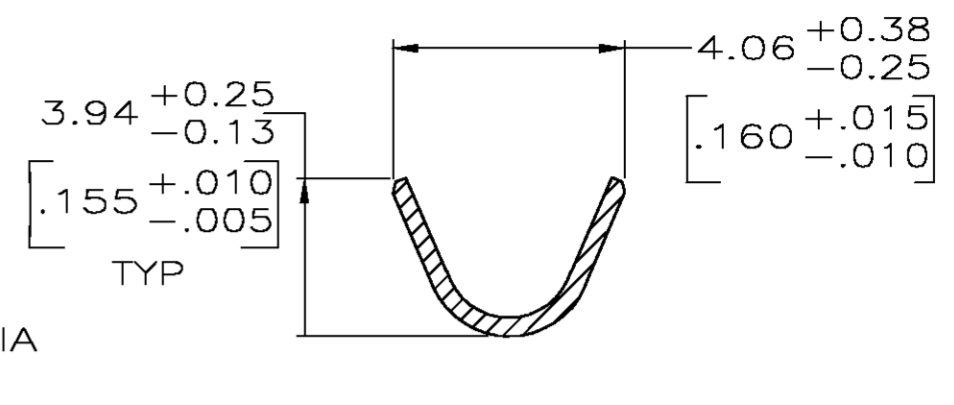

SECTION A-A

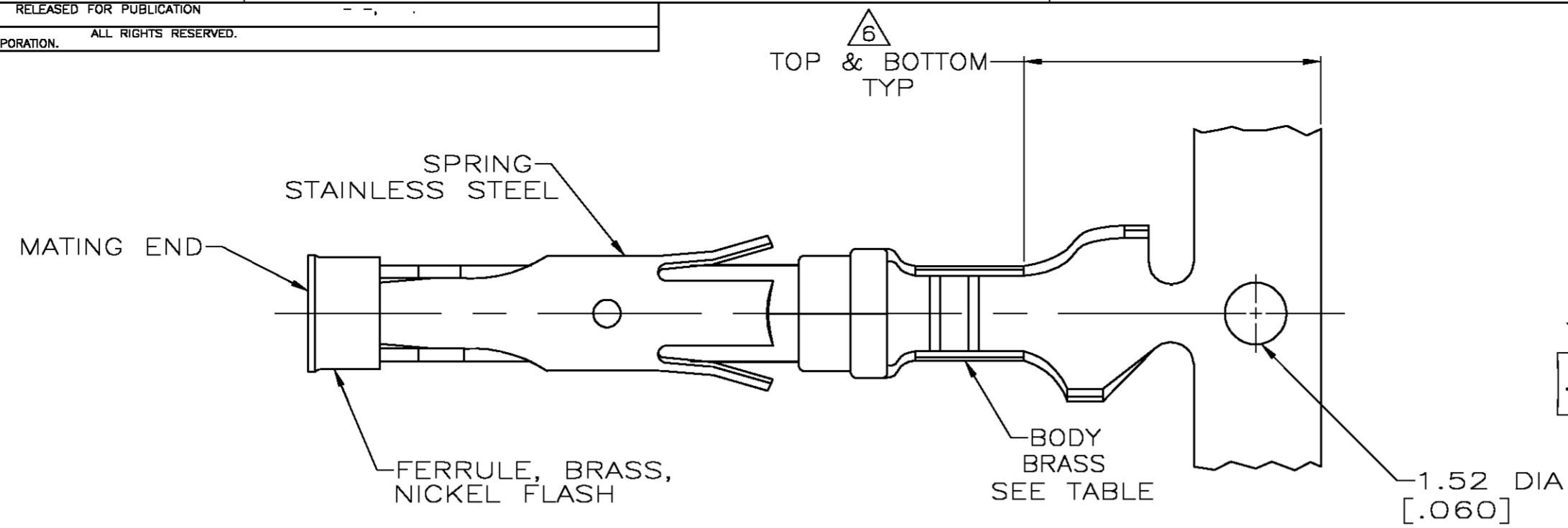
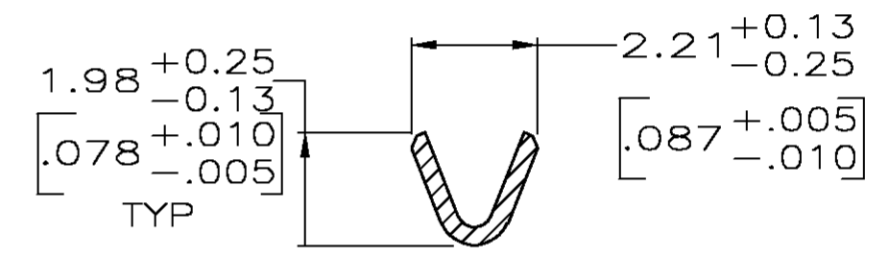
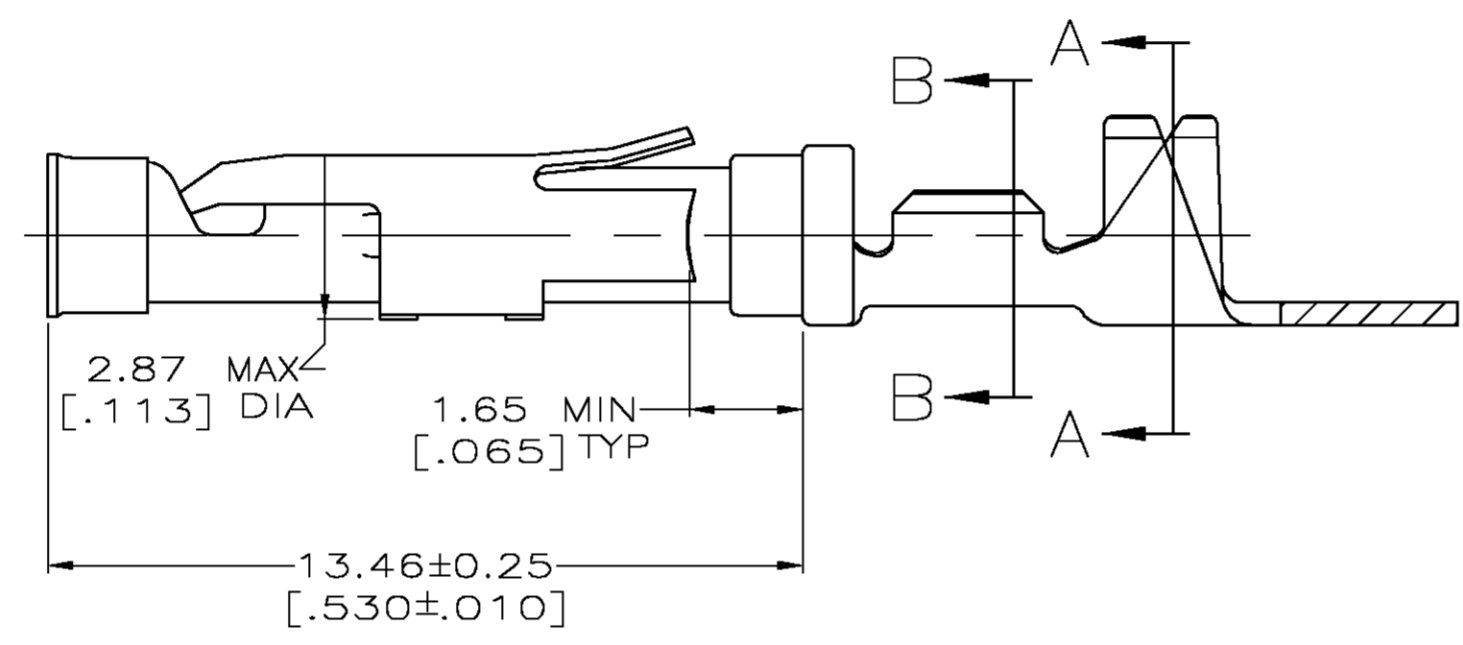
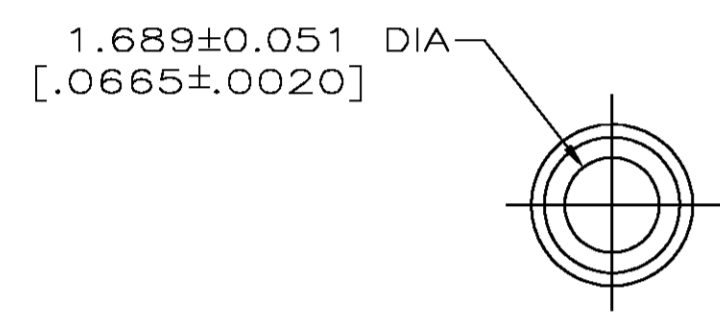

SECTION B-B

- ① 0.76 μm [.000030] MIN GOLD PER MIL-G-45204 ON MATING END FOR A LENGTH OF 5.08 [.200] MIN WITH GOLD FLASH ON THE REMAINDER OVER 0.76 μm [.000030] MIN NICKEL PER QQ-N-290.
- ② 1.27 μm [.000050] MIN TIN-LEAD PER MIL-T-10727 OVER 0.76 μm [.000030] MIN NICKEL PER QQ-N-290.
- ③ 0.76 μm [.000030] MIN GOLD PER MIL-G-45204 ON MATING END FOR A LENGTH OF 5.08 [.200] MIN WITH A UNIFORM GRADIENT TO 0.25 μm [.000010] MIN GOLD PER MIL-G-45204 ON THE REMAINDER OVER 0.76 μm [.000030] MIN NICKEL PER QQ-N-290.
- ④ 0.38 μm [.000015] MIN GOLD PER MIL-G-45204 ON MATING END FOR A LENGTH OF 5.08 [.200] MIN WITH GOLD FLASH ON THE REMAINDER OVER 0.76 μm [.000030] MIN NICKEL PER QQ-N-290.
- ⑤ 1.27 μm [.000050] MIN GOLD PER MIL-G-45204 ON MATING END FOR A LENGTH OF 5.08 [.200] MIN WITH GOLD FLASH ON REMAINDER OVER 3.81 μm [.000150] MIN NICKEL PER QQ-N-290.
- ⑥ GOLD PLATING NEED NOT APPEAR IN THIS AREA.
- ⑦ REVERSE REELED FOR MINI-APPLICATOR.
- ⑧ WIRE RANGE 24-20 AWG. INSULATION RANGE 1.52 [.060]-3.05 [.120].
- ⑨ 0.38 μm [.000015] MIN GOLD PER MIL-G-45204 ON MATING END FOR A LENGTH OF 5.08 [.200] MIN, 1.27 μm [.000050] MIN TIN-LEAD PER MIL-T-10727 FOR A LENGTH OF 5.69 [.224] MIN ON OPPOSITE END, BOTH OVER 1.27 μm [.000050] MIN NICKEL PER QQ-N-290 ON ENTIRE CONTACT.
- ⑩ 1.27 μm [.000050] MIN TIN PER MIL-T-10727 OVER 0.76 μm [.000030] MIN NICKEL PER QQ-N-290.
- ⑪ 1.27 m [.000050] MIN TIN PER MIL-T-10727 OVER 0.76 m [.000030] MIN NICKEL PER QQ-N-290.

	66565-7	⑦	⑩	1-66563-1
OBSOLETE	66565-5	⑦	⑨	1-66563-0
OBSOLETE	-	⑦	⑤	66563-9
	66565-4	⑦	①	66563-8
OBSOLETE	66565-3	⑦	④	66563-7
	66565-2	⑦	②	66563-6
	66565-1	⑦	③	66563-5
	66565-4	STANDARD	①	66563-4
	66565-1	STANDARD	③	66563-1
	LOOSE PIECE REF	REELING	BODY FINISH	PART NO

THIS DRAWING IS A CONTROLLED DOCUMENT.		DWN R.SHIREY 8-7-81	Tyco Electronics Corporation	
DIMENSIONS: INCHES		CHK R.STONE 9-19-91	City, State, Zip	
TOLERANCES UNLESS OTHERWISE SPECIFIED:		APVD J.WESTMAN 9-20-91	NAME	
0 PLC ± -		PRODUCT SPEC		
1 PLC ± -		APPLICATION SPEC		
2 PLC ± 0.13 [.005]		SIZE CAGE CODE DRAWING NO		
3 PLC ± -		A2 00779 C=66563		
4 PLC ± -		RESTRICTED TO		
ANGLES ± -		SCALE 8:1 SHEET 1 OF 1 REV R		
FINISH		CUSTOMER DRAWING		
MATERIAL SEE CALLOUTS		SEE CALLOUTS		